

Conquers any terrain you can throw at it.

The Firebird 27.5 has proven itself in everything from World Enduro competition to World Cup DH racing and every possible epic ride imaginable. It's a bike for those who like to push the boundaries on descents, but require a bike that is equally capable on the climbs. The Firebird has always been revered for its unique combination of climbing traction, acceleration, and descending capabilities.

Within our line of very versatile bikes it stands out because it truly rewards and inspires confidence for the most aggressive riders. With a slack head angle, low BB height, and World Cup DH influenced dw-link® suspension design, the Firebird 27.5 excels across a wide range of terrain with a tendency towards tackling the most extreme trails. With the Firebird 27.5 come new possibilities, higher speeds and record-breaking performance in extreme enduro racing, gravity riding or the occasional DH race.



Firebird Alloy 27.5 Features

- 6.6" (167mm) rear travel dw-link® suspension design with rearward wheel travel path, incredible square edged bump performance, and unparalleled pedaling efficiency.
- Pivot-specific, custom valved Fox Float or Float X CTD Kashima coated shock technology featuring increased rider tunability and incredible small bump sensitivity.
- Full 1.5 head tube with custom Pivot angled headset design optimizing the Firebird 27.5 as an ultimate Extreme Enduro machine.
- Patented Pivot floating front derailleur mount keeps the chain in the sweet spot of the derailleur for better chain retention. Combined with our custom ISCG 05 mounted MRP LRP 2X chain guide, our floating front derailleur mount creates perfect shifting performance and worry-free chain retention, even in the roughest conditions.
- 142mm rear spacing with 12mm through axle and 160mm post mount dropouts.

Frequently Asked Questions

Which size bike should I purchase?

To ensure the best sizing, we recommend that you visit your local Pivot dealer to get a professional fit and refer to our geometry chart to check your measurements. However, we can provide a rough guideline:

Small: 5'-5" – 5'9"

Medium: 5'9" – just under 6'

Large: 5'11" – 6'3"

What bottom bracket is used on the Firebird 27.5 and which cranks are compatible?

The Firebird 27.5 uses a threaded 73mm shell that is compatible with just about every possible MTB crank in the market.

What hub/wheel spacing does the Firebird 27.5 use?

The Firebird 27.5 uses the 142mm X 12mm hub/wheel spacing. Our custom 12mm DT Swiss axle is included with the frame. The axle is based off of Shimano's 12mm through axle specifications for length and thread pitch so if you were ever to lose your axle, a Shimano or Shimano compatible axle will work properly as well.

What size seatpost does the Firebird Alloy 27.5 use?

The Firebird frame uses a 30.9mm seatpost.

What size seat clamp does the Firebird Alloy 27.5 use?

The Firebird Alloy 27.5 frame uses a 34.9mm or 35mm (as some manufacturers call it) seatpost clamp.

Can I use a dropper post with this frame?

Yes, any dropper post with external routing will work on this frame.

What Is the Floating Front Derailleur System (FFD)

The Firebird features our patented variable position floating front derailleur mount. Big travel is the enemy of front shifting. However, our floating design maintains the correct relationship with the chain for better shifting and chain retention at every point in the travel. The Pivot FFD keeps the chain in the sweet spot of the derailleur for better chain retention. In addition, the floating mount is fully removable so that a single chainring chain guide can be easily installed to the Firebird's integrated ISCG05 mounts. No muss, no fuss, and a better ride for you!"

What front derailleur does the Firebird Alloy 27.5 use?

The Firebird Alloy 27.5 uses a Shimano E-type style, front derailleur mounted to our patented variable position floating front derailleur mount. If you are running a 2X or 3X Shimano systems with 10 speed rear cassette then use a Shimano direct mount FD. You will need to look at Shimano's technical specifications in order to source the correct Shimano E-type front derailleur for the front chainring combination you are using. If you are using a 22-36 double chainring setup on your Firebird, Shimano makes a SLX derailleur specifically for 2 ring set ups which is designed for a maximum 36 large ring. However, even a standard 3 ring E-type front derailleur will work fine with a 2-ring set up and a bash-ring.

Can I run a chain guide on the Firebird?

The Firebird uses a standard thread in BB so that we can accommodate ISCG05 (international standard chain guide system 05 version). We offer a custom MRP LRP 2 ring shift guide that works in conjunction with the Pivot floating front derailleur for perfect shifting performance and worry free chain retention in even the roughest conditions.

What headset do I need?

The Firebird features a 1.5" head tube (49.6mm ID) with a custom Pivot angled headset design. The custom Pivot angled headset is included with all Firebird complete bike models.

What travel fork can I use on my Firebird?

The Firebird was designed a 160mm fork. The maximum travel length that can be used on the Firebird is 170mm travel.

What Is the fork offset on the Firebird 27.5?

The fork offset on the Firebird 27.5 is 44mm.

How wide of a tire can I run on the Firebird?

The Firebird was designed to fit many 2.35 tires on a rim with a 23mm or greater inner width. We use the Maxxis High-Roller II 2.3 in our complete bike builds. For other tires in the market, most will fit, but rim width and tire manufacture sizing call outs and tire inconsistency can result in huge difference among both tire brands and individual tires. For tire brands other than Maxxis, we suggest you check the fit with your chosen rim and tire combination to make sure it has proper clearance before riding.

How large of a rotor will fit on the Firebird?

The Firebird was designed for either a 160mm or 180mm rotor. However, a 203mm rotor will clear as well.

What type of rear brake adapter do I need?

No brake adapter is needed for a 160mm rotor. However, many manufacturers make adapters for larger rotor sizes, in which case you would need a 160mm direct mount/ post to post adapter.

What Is the eye-to-eye shock length and stroke length on the Firebird?

The eye-to-eye shock length is 8.5 inches and the stroke length is 2.5 inches.

If I want to run a different brand of shock on my Firebird, what else do I need to know?

The Firebird shock uses M8 through bolt hardware on both the front and rear. Shock spacer dimensions are 22mm wide top and bottom. The frame is designed around a large volume air can. With the Fox shock, we run a +.4 or +.6 cubic inch volume spacer in the can to reduce the volume back down. We run medium compression valving and medium rebound damping. Although the Float CTD Kashima is the stock shock on the Firebird, we offer the Float X as an excellent upgrade option as well.

Can I put a coil-over shock on my Firebird?

In General, you cannot run a coil-over on your Firebird! The Firebird was designed to work with the progressiveness of an air spring. A coil-over shock (even one with separate bottoming control) does not offer the progressive spring curve that the Firebird requires. Running a coil-over shock on the Firebird will result in hard bottoming and damage to the frame. The one exception is the Fox RC4. It is possible to run this shock with the bottom out control turned at least 75% in (for near maximum bottoming control). Use of any other coil-over on the Firebird will void the warranty.

What are the torque specs?

A detailed PDF of the torque specs can be found under the "Tech Specs" tab.



Geometry Chart

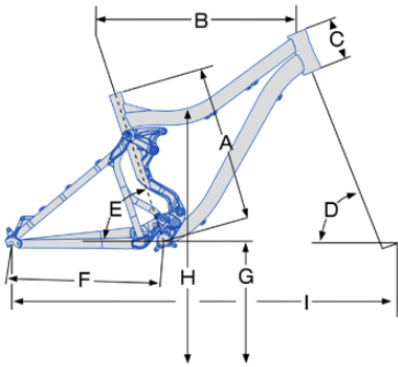

	S	M	L
A Seat Tube Length (C-T)	16.50	17.75	19.00
B Top Tube Length	22.50	23.00	24.00
C Head Tube Length	4.60	4.80	5.50
D Head Tube Angle	66.00°	66.00°	66.00°
E Seat Tube Angle	71.50°	71.50°	71.50°
F Chain Stay Length	17.25	17.25	17.25
G Bottom Bracket Height	14.10	14.10	14.10
H Standover Height	28.75	28.75	28.75
I Wheelbase	43.81	44.31	45.38
Stack	23.33	23.51	24.15
Reach	14.50	14.95	15.75

Values in inches

CM

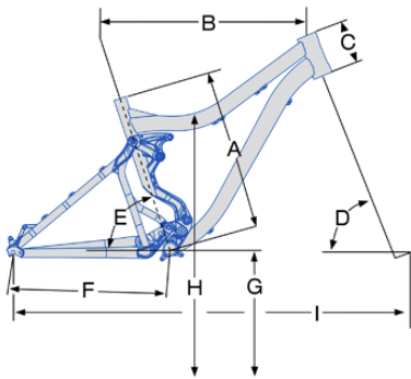

	S	M	L
A Seat Tube Length (C-T)	41.91	45.09	48.26
B Top Tube Length	57.15	58.42	60.96
C Head Tube Length	11.68	12.19	13.97
D Head Tube Angle	66.00°	66.00°	66.00°
E Seat Tube Angle	71.50°	71.50°	71.50°
F Chain Stay Length	43.81	43.81	43.81
G Bottom Bracket Height	35.81	35.81	35.81
H Standover Height	73.03	73.03	73.03
I Wheelbase	111.28	112.55	115.27
Stack	59.26	59.72	61.34
Reach	36.83	37.97	40.01

Values in centimeters

IN

FIREBIRD

NUMBER	PART NAME	DESCRIPTION	Torque	*
15	FP-LNK-LL-GLD-V5-R1	LINK LOWER GOLD VER5 REV1		
16	FP-BRG-6802-LLBMAX	6802 LLB MAX		
17	FP-SLV-LL-25MM	SLEEVE LOWER LINK 25MM		
18	FP-SLV-LL-28MM	SLEEVE LOWER LINK 28MM		
19	FP-LNK-UL-85MM-V2	LINK UPPER 85MM VER2		
23	FP-BRG-608-LLBMAX	608 LLB MAX		
24	FP-BRG-608-FE2RSSPMX	608 FE 2RS SP MX		
50	FP-BLT-M8*39-SIL	BOLT 8X39 SILVER	13 Nm (10 lb-ft)	●
51	FP-LNK-FD-SIL-V1-R1	LINK FRONT DERAILLEUR SILVER VER 1 REV 1		
52	FP-STP-FFD-V1	STOP FLOATING FRONT DERAILLEUR V1		
53	FP-WSH-51*90*15W	WASHER 51 X 90 X 15W		
54	FP-BRG-685-LLB	685 LLB		
55	FP-BRG-3802-2RSP	3802 2RS-P		
56	FP-CAP-LL-11I	CAP LOWER LINK 11ID		
57	FP-SCW-SCK-M6*10	SCREW SOCKET 6X10	7 Nm (5 lb-ft)	□
58	FP-SCW-BTN-M5*10	SCREW BUTTON 5X10	3 Nm (26 in-lb)	□
59	FP-SCW-RND-M5*25	SCREW ROUND 5X25	4 Nm (35 in-lb)	□
61	FP-SCW-FLT-M6*10	SCREW FLAT 6X10	5 Nm (44 in-lb)	□
63	FP-SCW-FLT-M5*12	SCREW FLAT 5X12	4 Nm (35 in-lb)	□
64	FP-SCW-FLT-M5*25	SCREW FLAT 5X25	4 Nm (35 in-lb)	□
65	FP-SPR-EXT-10.50*52.25	SPRING EXTENSION 10.5X52.25		
66	FP-BLT-M14*69-GLD	BOLT 14X69 GOLD	35 Nm (27 lb-ft)	●
67	FP-BLT-M8*17	BOLT 8X17	13 Nm (10 lb-ft)	□
68	FP-GDE-CHN-ISCG-V1	GUIDE CHAIN ISCG VER1		
69a	FP-RDH-QR-9MM-BLK-V1	REAR DERAILLEUR HANGER QR 9MM BLACK V1		
69b	FP-RDH-TA-12MM-BLK-V1	REAR DERAILLEUR HANGER THROUGH AXLE 12MM BLACK V1		
70	FP-WSH-UL-3MM-BLK	WASHER UPPER LINK 3MM BLACK		
71	FP-WSH-81*120*1W	WASHER 81 X 120 X 1W		
72a	FP-SCW-RND-M8*8	SCREW ROUND 8X8	7 Nm (5 lb-ft)	○
72b	FP-SCW-SCK-M5*10	SCREW SOCKET 5X10	7 Nm (5 lb-ft)	□
73	DT SWISS 142 RWS	DT SWISS 142 RWS		

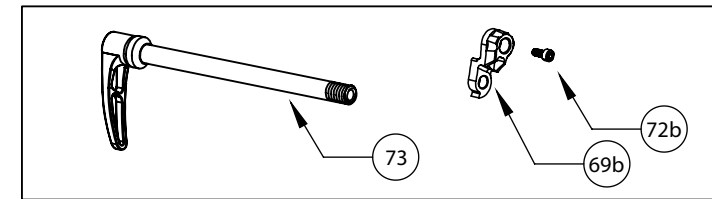
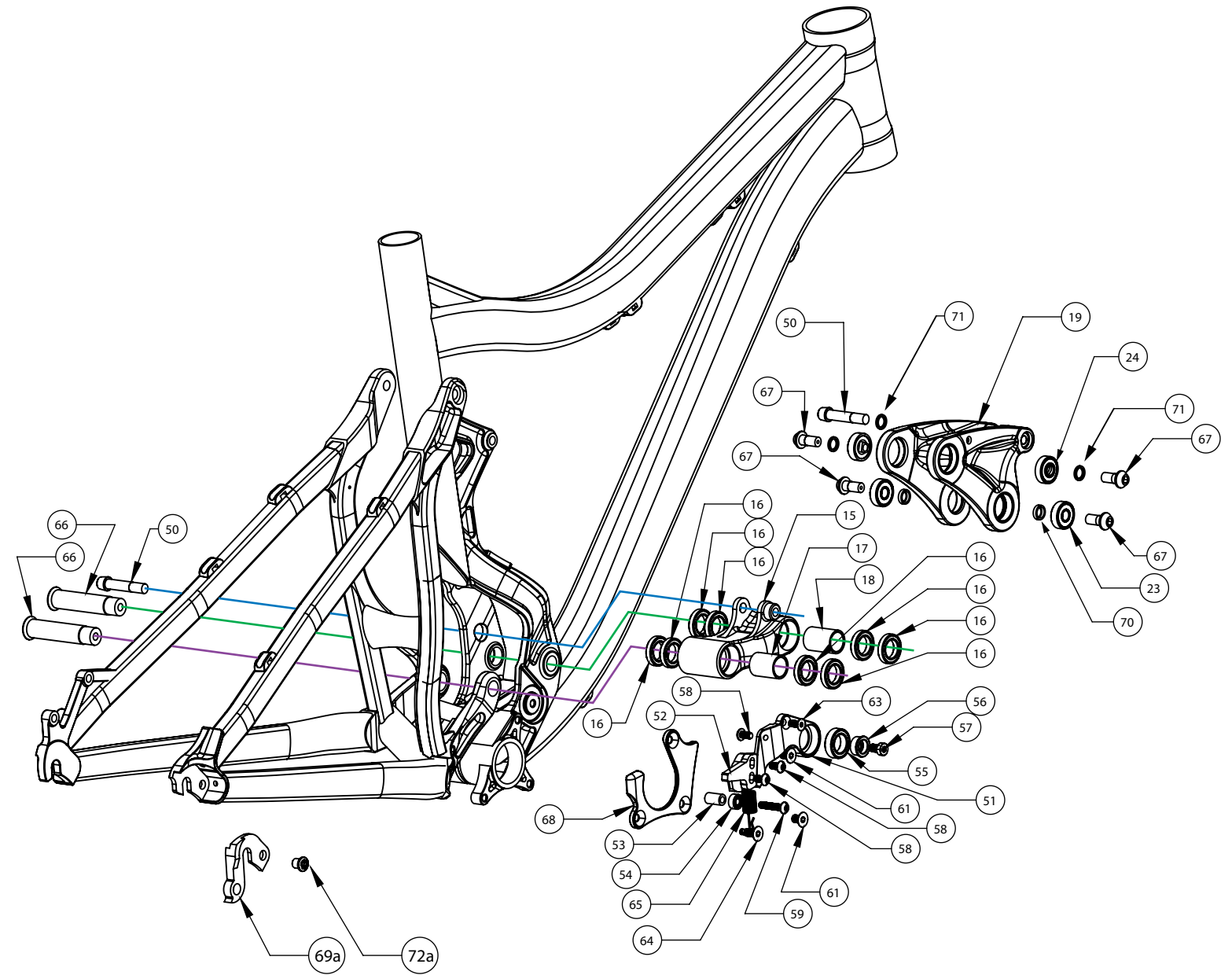

* ○ = grease ● = anti-seize ◐ = anti-seize or grease □ = loctite 243

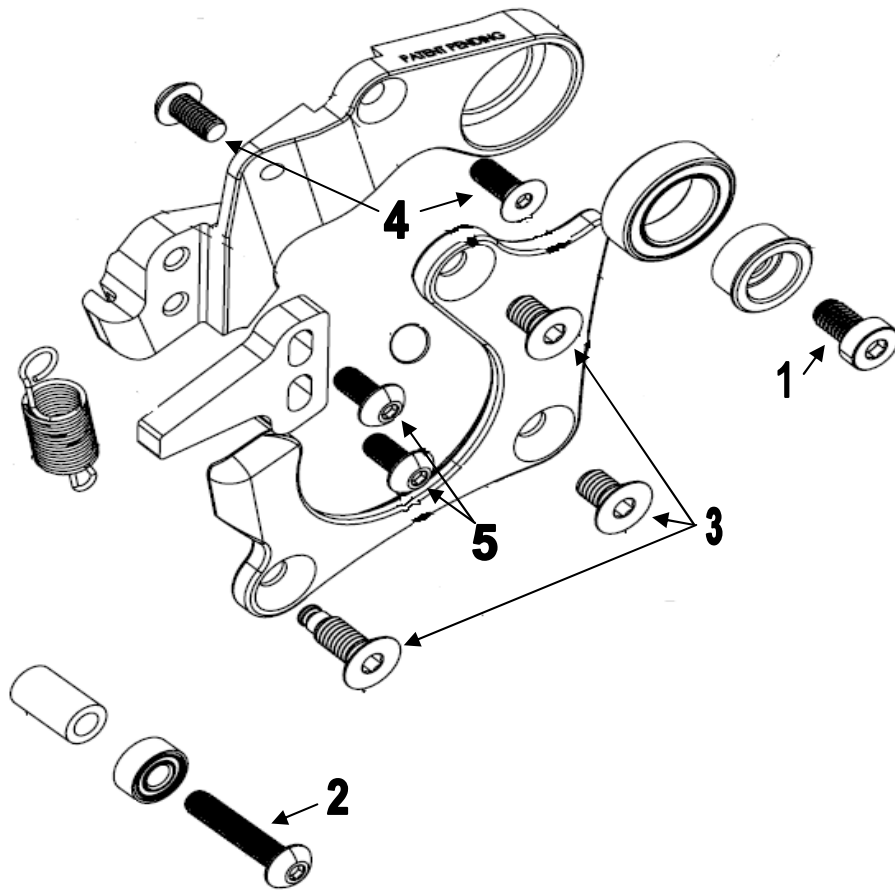

- 1) Front derailleur link mounting bolt is installed with blue Loctite 242 and torqued to (**5lb. Ft, 60 lb.in, 7 Nm.**)
- 2) Install 3mm front derailleur peg with blue Loctite 242 and torque to (**35 in-lb, 4 Nm.**)
- 3) Install black ISCG chain guide using blue Loctite242 and torque to (**44.3 in-lb, 5 Nm.**)
- 4) Install 3mm front derailleur bolts using blue Loctite 242 and torque to (**35 in-lb, 4 Nm.**)
- 5) Install 3mm peg tab bolts using blue Loctite 242 and torque to (**26 in-lbs, 3 Nm.**)



SUSPENSION SETUP GUIDE

For your Pivot suspension equipped bike to pedal and descend at its best, it is important to tune the suspension properly. Use this guide to familiarize yourself with the Pivot suspension setup procedures and as a baseline for tuning to your individual riding needs.

Document Contents:

- 1. Setting Sag on *FOX Float DPS* and *Float X* Rear shocks**
- 2. Setting Rebound damping on *FOX Float DPS* and *Float X* Rear Shocks**
- 3. Setting Compression damping on *FOX Float DPS* and *Float X* Rear Shocks**
- 4. Setting up *FOX Float X2 Air***
- 5. Setting up *FOX Float* air fork pressure**
- 6. Setting up *FOX Float* air fork compression and rebound damping**



Performance. Redefined.

1. Setting Sag on FOX Float DPS, and Float X Rear shocks

Always set sag with the compression adjust *blue* lever turned to the open position (see section 3 for details on this setting).

1. If it is not installed already, attach the sag indicator to the bottom of the shock body using the provided zip-tie. (fig 1)
2. Have the rider stand on the pedals, preferably with their hydration pack on, and have them sit down hard into the saddle to achieve accurate sag settings. The rider does not need to bounce up and down nor should they sit down gently. If they sit down hard once, the suspension will cycle well into the stroke and return to the natural sag setting with the rider in the saddle.
3. With the rider in the saddle and not moving, slide the O-ring up into position against the air can. (fig 3)
4. Once the O-ring is set in place, have the rider slowly step off the bike so as not to move the O-ring.
5. Make adjustments to the sag by removing or adding air so that steps 2-4 result in the O-ring lining up with the red line on the sag indicator (fig 5). Some of our models feature a sag indicator with both a blue line (RACE) and a red line (TRAIL). You can set the sag anywhere in this range to achieve a firmer or plusher overall feel depending on rider preference. *For shocks with the EVOL can:* It will be necessary to cycle the shock after adding or subtracting air before re-checking sag as the large Evol negative air chamber will need to equalize pressure with the main chamber each time air is added or removed. You can do this by pushing down on the saddle several times to compress the shock past the sag point. It is OK to do this with the shock pump still attached to the shock as it will let you know how much the pressure increases or decreases after the Evol negative air chamber balances with the main chamber.

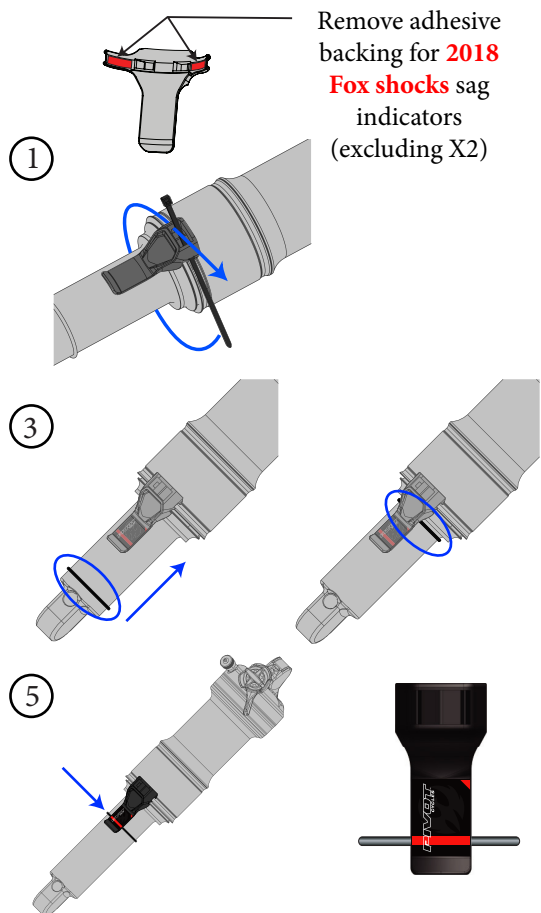

Remove adhesive backing for **2018 Fox shocks** sag indicators (excluding X2)

WARNING: MAKE SURE TO ROTATE SAG INDICATOR TO BOTTOM OF SHOCK BEFORE RIDING TO ENSURE THAT IT DOES NOT BREAK OFF WHEN SUSPENSION CYCLES

If there is no sag indicator on the shock, use the measurements listed below to determine sag. Different models and sizes of Pivot bikes use different length shocks and therefore require different sag settings.

Indicator A* Sag: 0.74" (18.8mm)*	Indicator B Sag: 0.65" (16.5mm)	Indicator C Sag: 0.49" (12.4mm)	Indicator D Sag: 0.55" (14.0mm)
Bikes: • Mach 5.7 • Mach 5: M-XL • Mach 6 Carbon* • Mach 6 Alloy* • Firebird*	Bikes: • Switchblade • Mach 5.5 • Mach 5.7 Carbon • Mach 4: S-XL (2010 & Older) • Mach 5: XS-S • Mach 429 Alloy	Bikes: • Mach 4: XXS-XS	Bikes: • Mach 4: S-XL (2011 & Newer) • Mach 429 Carbon • Mach 429 SL • Mach 429 Trail

*Sag Measurement: 0.80" (20.3mm); set between the red line and the end of the indicator

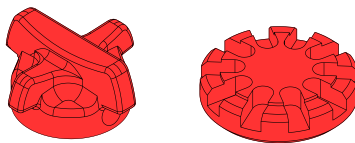

2. Setting Rebound damping on FOX Float DPS and Float X Rear Shocks:

We set rebound from the most open or fastest position, so start by turning the *red* rebound dial counterclockwise all the way out and then follow the guidelines below per model:

- Mach 4, 429SL, and Mach 5.7: Turn *red* dial in clockwise 0-6 clicks in depending on rider weight. A sub 130lb rider is at the full out or fastest setting. Average is 4 clicks in.
- Mach 429 Trail: Turn *red* dial in clockwise 3-8 clicks in depending on rider weight. Average is 5 clicks in.
- Switchblade and Mach 5.5: Turn *red* dial in clockwise 5-10 clicks in depending on rider weight. Average is 6 clicks in.
- Mach 6 or Firebird with Float X or Float DPS: Turn *red* dial in clockwise 9-13 clicks in depending on rider weight.

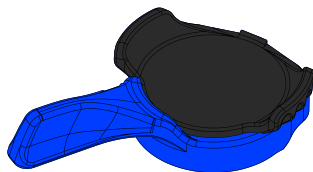

3. Setting Compression damping on FOX Float DPS and Float X Rear Shocks:

Because all dw-link® equipped Pivot bikes pedal so efficiently, we use the compression lever as a tuning tool for rider weight and compression support. All bikes can be run with the *blue* lever in full open and perform very well. On Float DPS shocks, this means the lever is turned towards the opposite side of the air valve. In the case of the Float X, this means that the lever will be flipped towards the remote reservoir. Lighter riders under 160lbs will generally run in the full open position most of the time. Riders in the 170lb+ range and more aggressive riders who like the feel of more mid-stroke support will generally prefer the middle setting. The firm setting is great for your ride to the trail, long fire road climbs, and smooth XC race courses where a more locked out feel is desired.

All Factory Series Float X and Float DPS shocks also feature three additional options that affect the open setting via the *black* knob. This knob needs to be lifted slightly to turn to one of the three designated options. #1 is the most open, or least amount of compression damping, and #3 is the firmest (but still slightly less firm than the middle position of the *blue* lever). You can experiment with all of these options to find the setting that provides the best compression support and plushiest feel for your weight and riding style. Other than running in the full firm mode on rocky descents, all settings are designed to work well in a wide variety of terrain and rider weights.



4. FOX Float X2 Air:

Start by setting sag using the same process as the Float X and Float DPS shocks (page 2). The sag indicator on this shock is located on the oil reservoir rather than attached to the air sleeve. If there is no sag indicator on the oil reservoir use the measurements listed below to determine sag. Different models and sizes of Pivot bikes use different length shocks and therefore require different sag settings. The bike models for each sag setting are listed under the respective diagrams.

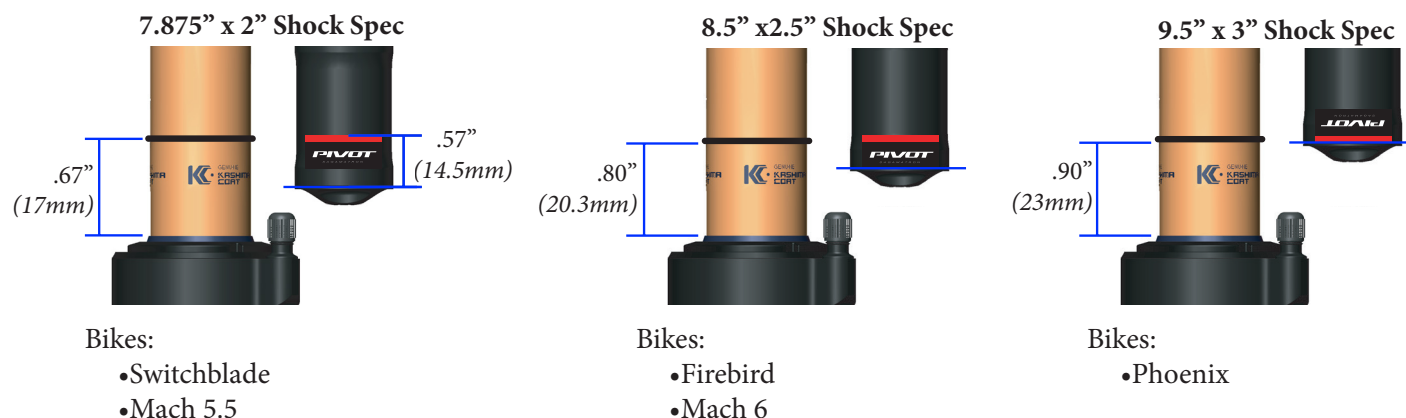

Damping Adjustments

The X2 air shock has tuning options well beyond the scope of what we can cover here. Not only can the shock be tuned through the use of the HSC, LSC, HSR, and LSR knobs, but it can also be tuned via the amount of air pressure in the shock and the addition or removal of air volume spacers to change the spring curve characteristics. We have settled on an air spring curve that has proven to be optimized for a wide range of riders from a sport level to our World Cup DH team, so changing the Pivot factory air spring curve characteristics is not really necessary.

We recommend 30% sag on the Float X2 Air. Based on this sag setting you can record your air pressure and use FOX's tuning chart copied on the right to set your *High Speed Compression* damping (HSC), *Low Speed Compression* damping (LSC), *High Speed Rebound* damping (HSR), and *Low Speed Rebound* damping (LSR). These settings are also applicable to Performance series Float X2 air shocks that feature only the LSC and LSR adjustments.

The suggested settings differ based on the which model year shock is spec'd on your bike. The performance of the shocks are identical between model years, however, due to valving changes, the suggested settings have shifted in the usable range of the tuning options. To determine which shock is spec'd on your bike look for a set screw on the bottom of the air can, in line with the fill valve. The 2018 shocks will have a set screw, the 2017 shocks will not. The photos below will help illustrate the difference between the shocks.

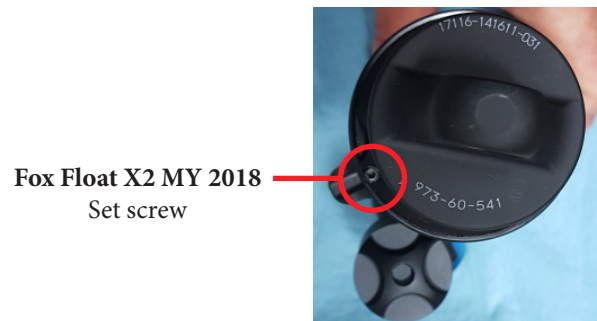

Suggested Tuning by Air Pressure

Suggested settings for MY17 shocks*				
Air Spring Pressure	Baseline LSR (3mm hex)	Baseline HSR (6mm hex)	Baseline LSC (3mm hex)	Baseline HSC (6mm hex)
90	Open	1-3	Open	Open
100	Open-2	2-4	Open-1	Open-2
110	1-3	3-5	Open-2	1-3
120	2-4	4-6	Open-2	2-4
130	2-4	5-7	1-3	3-5
140	3-5	6-8	1-3	3-5
150	4-6	6-8	2-4	4-6
160	4-6	7-9	2-4	4-6
170	5-7	7-9	3-5	5-7
180	5-7	8-10	4-6	6-8
190	6-8	8-10	4-6	6-8
200	7-9	9-11	5-7	7-9
210	8-10	9-11	6-8	8-10
220	9-11	10-12	6-8	8-10
230	10-12	10-12	7-9	9-11
240	11-13	11-13	8-10	9-11
250	12-14	11-13	8-10	10-12

Suggested settings for MY18 shocks*				
Air Spring Pressure	Baseline LSR (3mm hex)	Baseline HSR (6mm hex)	Baseline LSC (3mm hex)	Baseline HSC (6mm hex)
90	Open-2	5-7	2-4	1-3
100	Open-2	6-8	3-5	3-5
110	3-5	7-9	4-6	4-6
120	4-6	8-10	4-6	5-7
130	4-6	9-11	5-7	6-8
140	5-7	10-12	5-7	6-8
150	6-8	10-12	6-8	7-9
160	6-8	11-13	6-8	7-9
170	7-9	11-13	7-9	8-10
180	7-9	12-14	8-10	9-11
190	8-10	12-14	8-10	9-11
200	9-11	13-15	9-11	10-12
210	10-12	13-15	10-12	11-13
220	11-13	14-16	10-12	11-13
230	12-14	14-16	11-13	12-14
240	13-15	15-17	12-14	12-14
250	14-16	15-17	12-14	13-15

*Count clicks from open. 0 clicks = Open (fully turned counter-clockwise)

In general, we are running the rebound settings at the slower end of the range provided at each pressure and the compression settings at the lighter end of the provided range. For example, if you are running 200psi in the shock, the range for LSR is listed as 7-9 clicks in from open; We recommend starting at 9. For HSR the range is 9-11 clicks in from open; We recommend starting at 11. On the compression side for LSC, at 200psi in the shock, the range is 5-7 clicks in from open; We recommend starting at 5 clicks in. For HSC the range is 7-9 clicks in from open; We recommend starting at 7. If you follow this same process for the pressure that you are running then you'll have an excellent starting set up that may not require any further adjustment.

For further detail, FOX provides a complete tuning guide for the Float X2 Air shock on their website at www.ridefox.com

5. FOX Float Air Fork Pressure:

To set fork sag use the charts below as a recommended starting point:

RIDER WEIGHT (lbs)	32 FLOAT Pressure	34 FLOAT Pressure	36 FLOAT Pressure
120-130	57 psi/ 3.9 bar	45 psi/ 3.1 bar	40 psi/ 2.8 bar
130-140	61 psi/ 4.2 bar	48 psi/ 3.3 bar	41 psi/ 2.8 bar
140-150	66 psi/ 4.5 bar	51 psi/ 3.5 bar	43 psi/ 3.0 bar
150-160	71 psi/ 4.9 bar	53 psi/ 3.7 bar	46 psi/ 3.2 bar
160-170	76 psi/ 5.2 bar	56 psi/ 3.9 bar	51 psi/ 3.5 bar
170-180	82 psi/ 5.6 bar	58 psi/ 4.0 bar	55 psi/ 3.8 bar
180-190	87 psi/ 6.0 bar	63 psi/ 4.3 bar	59 psi/ 4.1 bar
190-200	92 psi/ 6.3 bar	68 psi/ 4.7 bar	63 psi/ 4.3 bar
200-210	98 psi/ 6.7 bar	72 psi/ 5.0 bar	67 psi/ 4.6 bar
210-220	103 psi/ 7.1 bar	77 psi/ 5.3 bar	71 psi/ 4.8 bar
220-230	108 psi/ 7.4 bar	82 psi/ 5.6 bar	75 psi/ 5.2 bar
230-240	113 psi/ 7.8 bar	86 psi/ 5.9 bar	79 psi/ 5.4 bar
240-250	119 psi/ 8.2 bar	91 psi/ 6.3 bar	83 psi/ 5.7 bar

6. FOX Float Air Fork Rebound and Compression Damping:

Setting rebound damping on FOX Forks:

We set rebound from the most open or fastest position, so start by turning the *red* rebound dial on the bottom of the right fork leg counterclockwise all the way out and then follow the guidelines below:

- **Float 32, 34, 36 Fit:** Turn *red* dial clockwise in 5-8 clicks in (depending on rider weight). Most riders are safe with 6 clicks in as a starting point.

Setting Low Speed Compression damping on FOX Forks:

We set compression from the most open or fastest position, so start by turning the *black* compression inner dial on the top of the right fork leg counterclockwise all the way out and then follow the guidelines below:

- **Float 32, 34, 36 Fit:** Turn black dial clockwise in 2-8 clicks in (depending on rider weight). Most riders should feel comfortable with 5 clicks in as a starting point. A rider under 120lbs would start with 2 clicks in.

Setting Up Your Sag Indicator (Meet Your New Travel Companion)

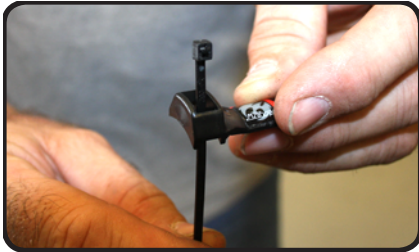

1

- Insert the supplied zip tie into your Sag Indicator, making sure the head of the zip tie is facing outward.



2

- Place the Sag Indicator above the bottom collar of the shock body.
- Tightly pull zip tie tail until indicator is tightly secured to shock before cutting excess.
- Cut excess zip tie.



3

- The Sag Indicator will rotate around the shock body if it is properly installed. Use your Suspension Set Up Guide (provided separately) to ensure proper sag.

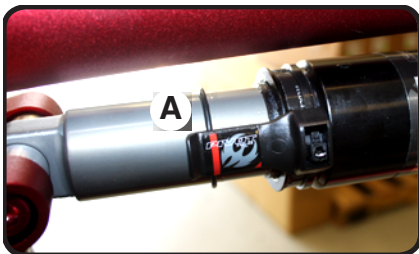

4

- You will know you've achieved proper sag when the rubber gasket aligns perfectly with the red line on the Sag Indicator (A).



You **MUST** rotate the Sag Indicator to the bottom of the shock body before riding! (B) Otherwise you risk breaking and losing the Sag Indicator.



Direct Mount Rear Derailleur Hanger



Pivot drop out type V1



Pivot drop out type V2

The Shimano Direct mount rear derailleur hanger was designed to be used with the drop out style V2.

If you have the drop out style V1 and would like to use the Shimano direct mount hanger a small modification to the drop out must be done.

You must remove the lower edge of the drop out flange.
(see photos below)



FIREBIRD 27.5



The Firebird has always been revered for its unique combination of climbing traction, acceleration, and descending capabilities.

The new Firebird 27.5-inch takes everything that's great about the original and makes it better. Within our line of very versatile bikes it stands out because it truly rewards and inspires confidence for an aggressive rider.





ALUMINUM TECHNOLOGY



In the Beginning

When we launched Pivot Cycles in 2007, we set out to develop the best mountain bikes in the world (regardless of material) and what developed was a line of aluminum bikes that set new benchmarks performance, weight and stiffness. Now nearly 6 years in, we've continued to develop, refine and re-define our line of aluminum full-suspension bikes so that these models would continue to be the best performing bikes in the world.

We go about things in a very different manner here at Pivot. You could definitely say we take the high road to building the best aluminum bikes in the world.

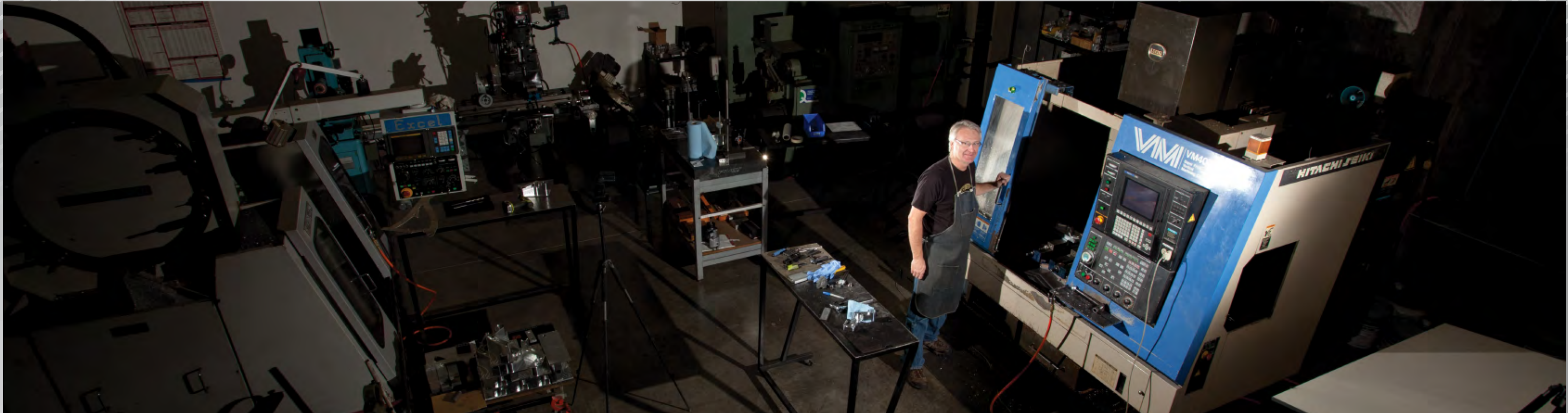

Proto-typing

First and Foremost, we have full manufacturing and proto-typing capabilities within our factory in Tempe, Arizona. Every Pivot alloy frame begins on the drawing board, but quickly moves to proto-typing within our own building. We have 4 CNC machining centers, mills, lathes, frame jigs, tube forming, welding, and testing capabilities in house.

It is common for a new model to have been through as many as 6 different proto-type variations and been in development for 2 years before it ever enters into production. Having these capabilities at Pivot gives us an advantage that few of our competitors have.

Proto-typing Continued

When we develop a new model, the tooling to produce that model is made in house. We develop everything needed to move the bike to production in the manner in which we want it made. We control every detail from how the tubes and parts are loaded into the fixture, how the frame is tacked and the order in which it is welded, checked, aligned and final machined.

Often times for a new model, the first 50 -75 bikes are made in house before we bring the bikes to production.

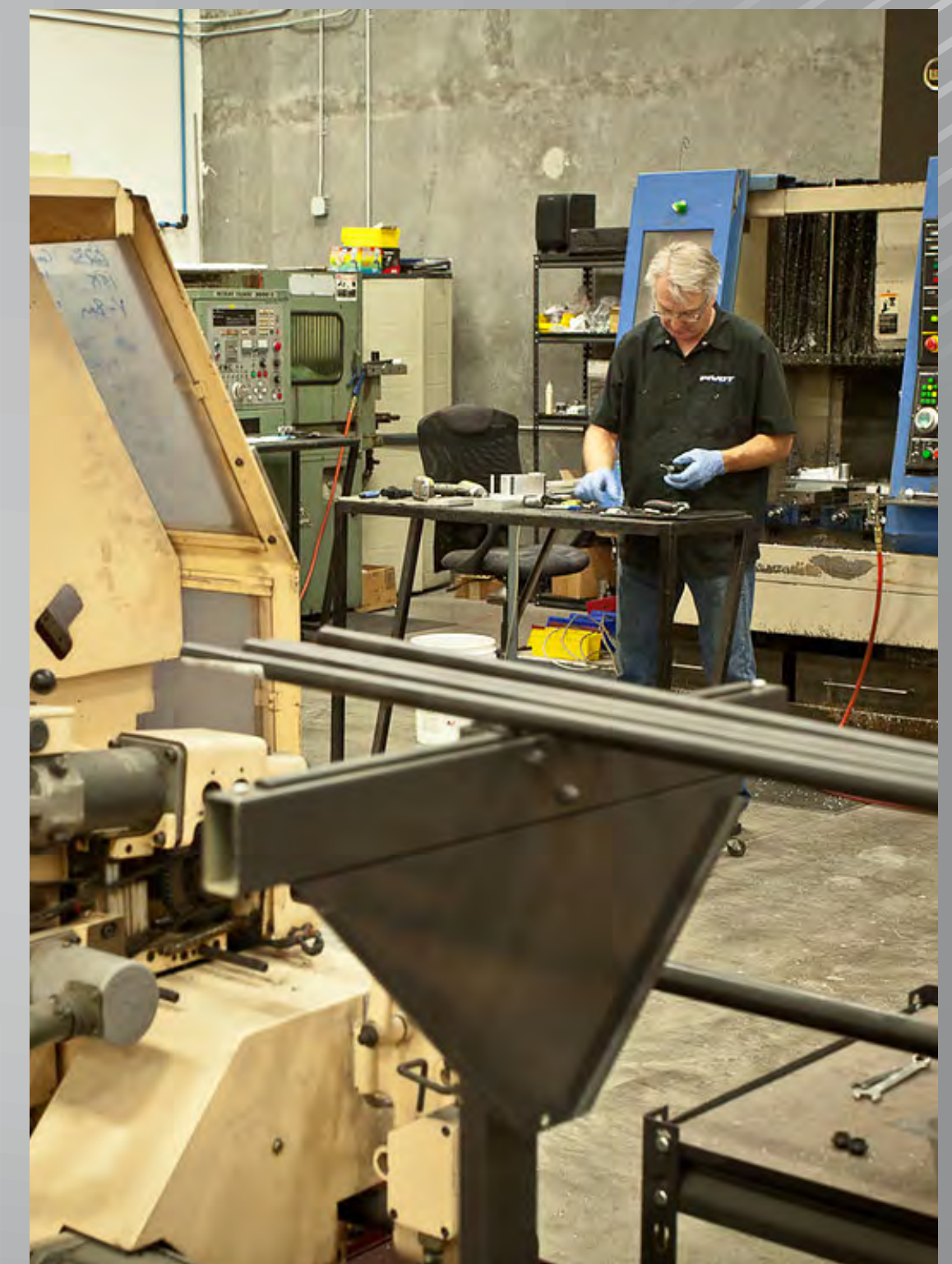
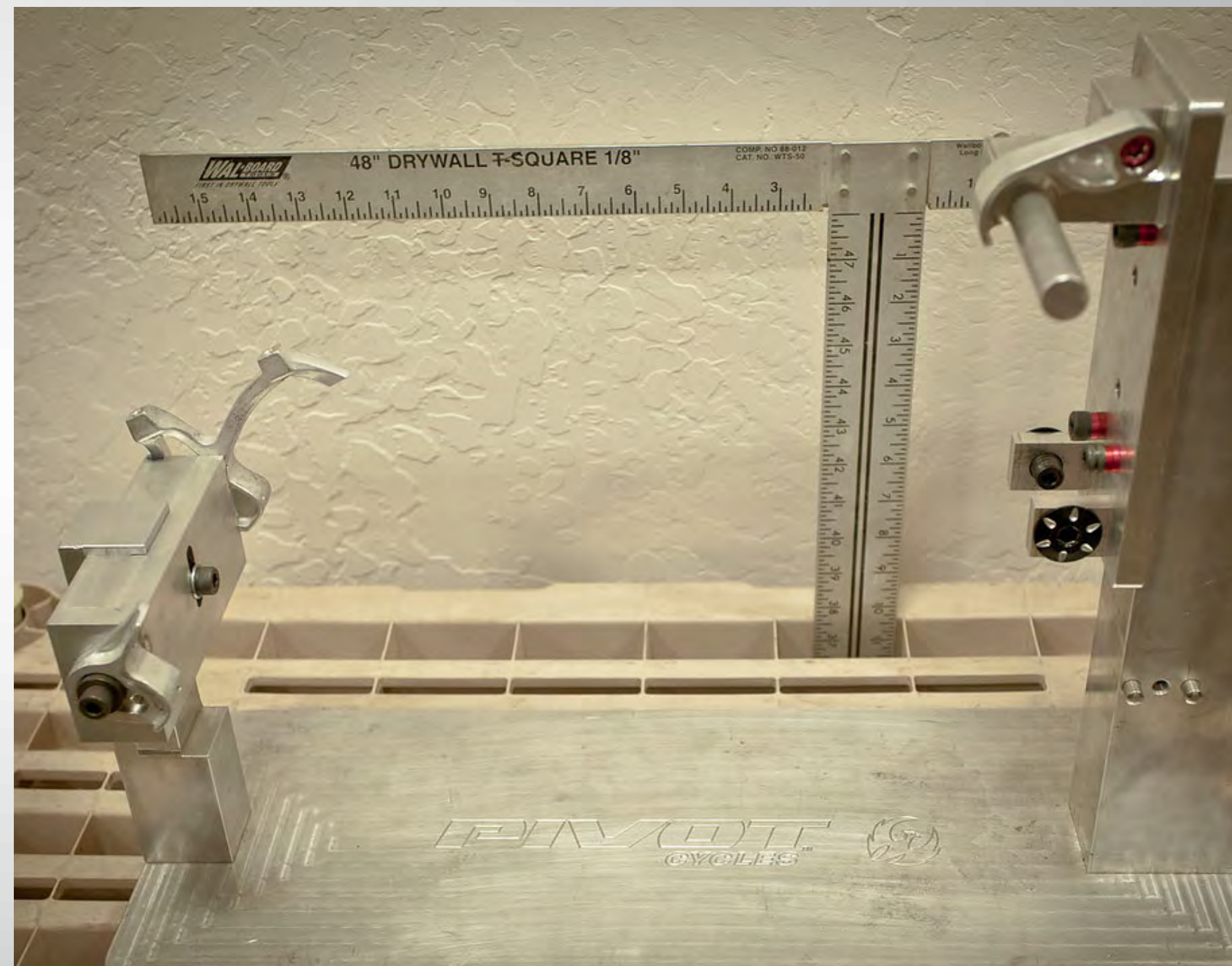

So why don't we just build the bikes in house?

Our goal is to manufacture the best bikes in the world and to do that we need to employ the best manufacturing capabilities in the world. In this case, Taiwan is the place. [We wanted the best tube forming, forging, heat treating, and finishing capabilities for building bicycles and it is no secret that Taiwan is the world leader for bicycle production.](#) The key is to have a manufacturing partner that can harness these capabilities and manufacture a Pivot to our high standards.

Fortunately, we have a close partner in Taiwan that Chris has known for over 10 years. They are a relatively small, family owned company that has been producing high end road frames for a small number of the most elite companies in the world (many of the names might surprise you). They have a penchant for high quality and a pride in their work that matches our own. With our partnership, we developed the process for building Pivot frames. We have our own production and assembly line as well as warehousing within their factory. Their family is like our family. The same people have been welding and assembling Pivot frames since the day we began.

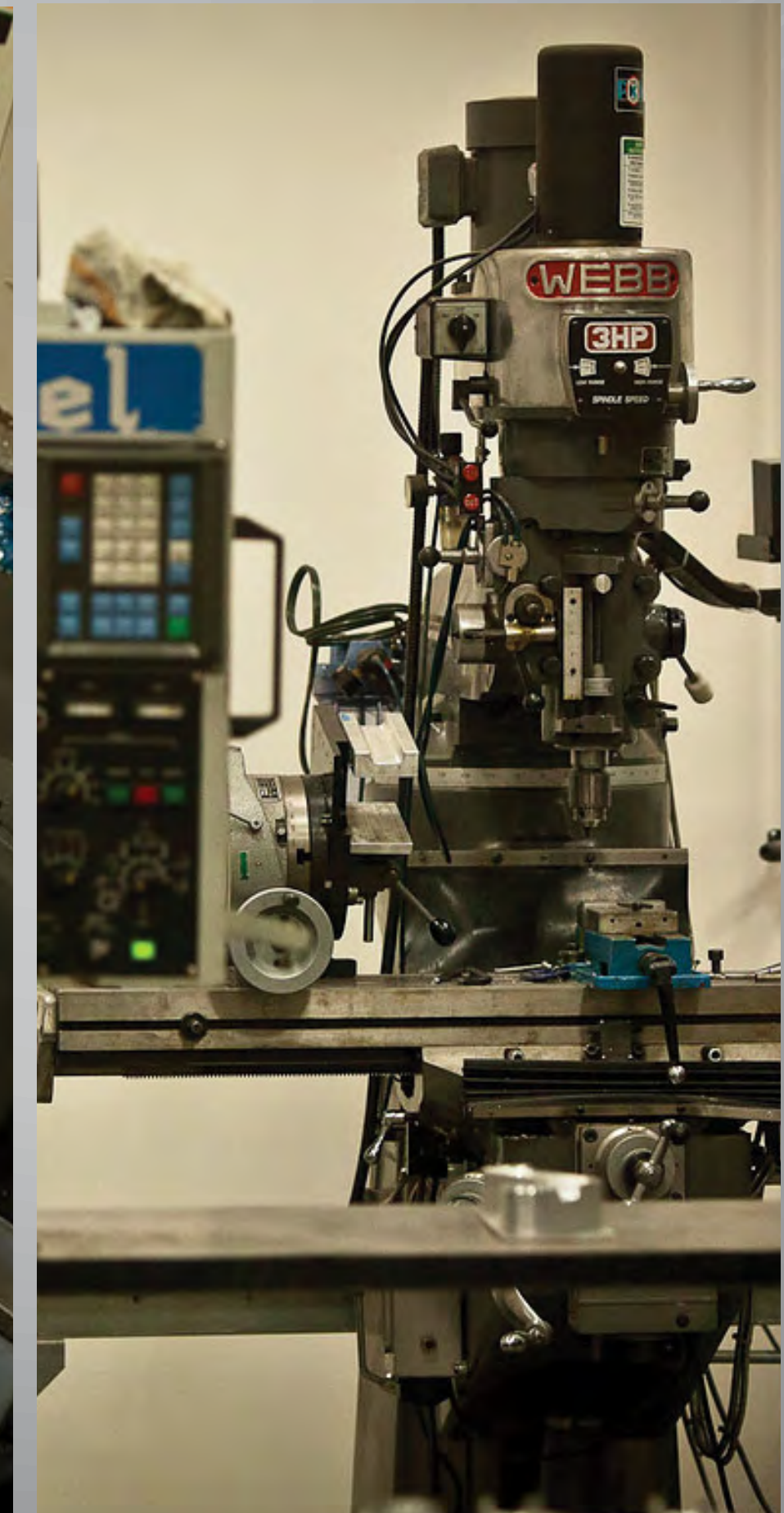

But, there is still more to the story....



It's not enough that we proto-type in house, develop the manufacturing process, and train our partners to build our bikes. There's so much more to it than that. For many things, we continue to manufacture in house, supply from the US, or look outside of the bicycle industry to push the boundaries of what is possible.

Some of the higher tolerance hardware and machined parts used in our Alloy frames are manufactured at Pivot and sent over to be welded and/or assembled into our frames. We also use a proprietary weld rod that is US made, and results in a stronger, better looking weld. It is about 5 times as expensive but produces a better frame so we send it from the US to Taiwan so that we know we are producing only the best products in the world.

One of the areas where we have really pushed the limits in our frame designs is in forging technology.

Look at the bottom bracket area of any Pivot alloy frame and you can see that we really have something truly unique going with designs that focus on frame stiffness, high tolerances and light weight. The bottom bracket area (and several other forged parts) on our frames are made using a 3D forging process that is not common to the cycling world. To achieve our design goals on these parts we went outside the industry to a company that produces the A-arm forgings for BMW's M and Audi's R series vehicles. This is just another example of how we are redefining what is possible by pushing the boundaries of technology and manufacturing in order to produce the best bikes in the world.





Quality Control

Every Pivot frame is assembled and then checked by a Pivot employee. We go through 28 detailed steps to make sure your Pivot frame is absolutely perfect.

No detail is left to the imagination and our ultimate goal is to deliver a bike that exceeds your every expectation. We like to think of our frames as a functional piece of engineering art where everything has a purpose, every detail has a function and ultimately what you experience is a bike where the technology is seamless and the ride is perfection.

We are Technology Redefined!

A Pivot frame is much more than the sum of its parts. The passion, detail and level of caring that goes into each and every Pivot frame sets us apart.



Lightweight frames and builds

Ultra-lightweight, with a stiffness to weight ratio that puts all other premium XC frames to shame. Race team bikes are being built as light as 20lbs (9kg)-Jason English's World Championship winning Mach 4 and we offer a 21.8 lbs (9.8kg) XX1 equipped Mach 4 as well.



Tapered 1.5' Headtube

Wider head tube allows us to take full advantage of oversized tubes to create amazing stiffness to weight ratios while keeping the ride quality at what you expect from a Pivot.



160mm Direct Mount Rear Brake Posts

160mm post mount bosses mount calipers directly to rear triangle resulting in higher levels of stiffness and lower overall system weight.

142 X 12mm through axle design

142 X 12mm through axle is designed with a forged 7075-T6 derailleur hanger and an integrated axle nut adds even more stiffness to the one piece rear triangle



Press Fit 92 BB

PF92 bottom bracket 92mm shell developed by Pivot with Shimano allows for wider pivots and better bearing support for increased frame strength and stiffness while maintaining better control over the bike's chain-line for optimal shifting performance and accuracy.



DW-Link with Carbon Top Plate

Hollowed from the inside out for maximum weight reduction and capped with a carbon top plate for incredible stiffness. Pivot alloy frames feature a dw-link with a unique double row bearing design bringing an even higher level of bearing durability and frame stiffness to all our aluminum frame designs.



Forged Alloy Derailleur Hanger

Forged 7075-T6 derailleur hanger with integrated axle nut.



Direct Mount Front Derailleur

Pivot alloy frames feature a direct mount e-type front derailleur design developed to be stiffer, lighter and offer more precise. The design allows for ease of set up and perfect front shifting.



Oversized Bearings

Oversized bearings all around and dual row Enduro Max bearings in the lower link for increased stiffness and durability.



Under Top Tube Cable Routing

Provides clean and effective cable management.

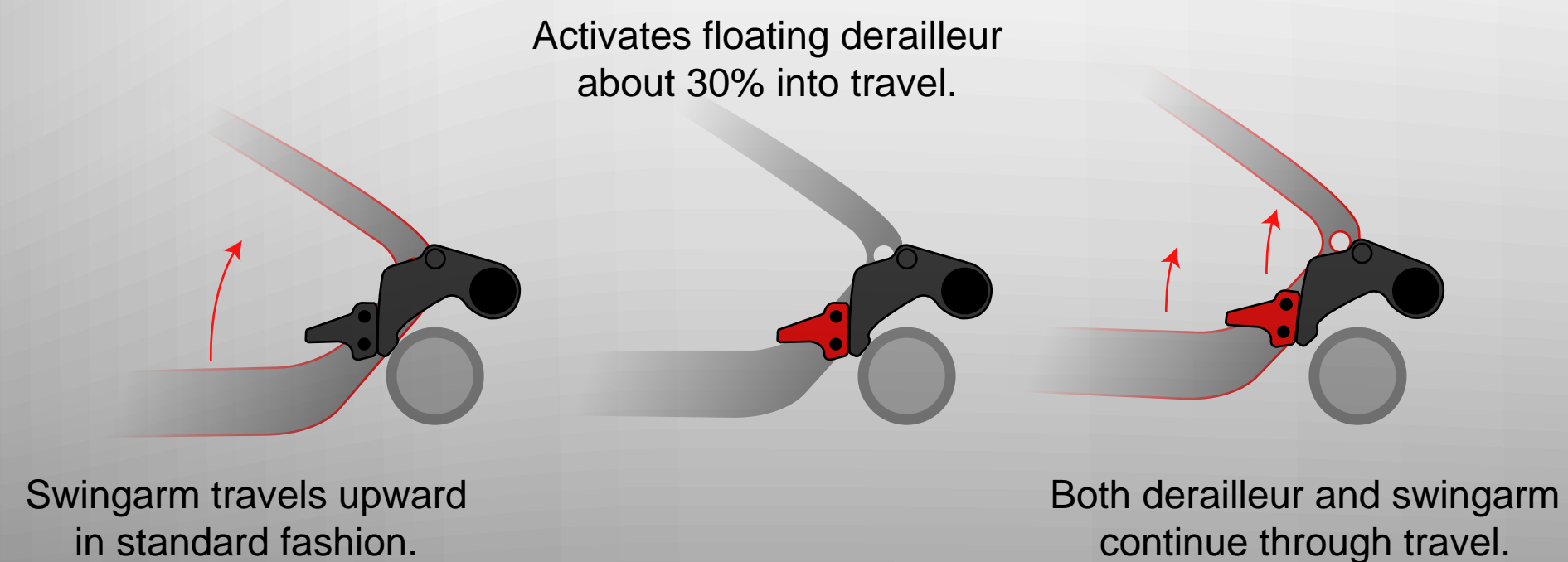

Patented **floating front derailleur** mount keeps the chain in the sweet spot of the derailleur for better chain retention. It also allows for a lighter, stronger frame design because the chainstay can run in line with the center of the bottom bracket without derailleur clearance issues.

This combined with our custom MRP LRP 2x chain guide for perfect shifting performance and worry free chain retention in even the roughest conditions.



73mm threaded BB shell compatible with all threaded BB designs for maximum compatibility with products in the long travel trail/gravity category. Includes ISCG 05 mounts.

Full 1.5 head tube with custom Pivot angled headset design optimizes the 27.5" Firebird making it the ultimate extreme enduro machine.



142mm x 12 rear through axle
and 160mm post mount dropouts
for maximum frame stiffness.



Pivot Specific, custom valved Fox Float or
Float X CTD shock technology featuring
increased rider tunability and incredible
small bump sensitivity.